

PLUS
420 | 05.13

SFA



SANIPLUS®

FR NOTICE D'INSTALLATION

UK INSTALLATION INSTRUCTIONS

DE INSTALLATIONSHINWEISE

IT STRUZIONI PER L'INSTALLAZIONE

ES MANUAL DE INSTALACIÓN

PT MANUAL DE INSTALAÇÃO

NL INSTALLATIE VOORSCHRIFTEN

SE INSTALLATIONSANVISNING

DK INSTALLATIONSVEJLEDNING

NO INSTALLASJONSANVISNING

FI ASENNUSOHJEET

HU FELSZERELÉSI ÉS KEZELÉSI ÚTMUTATÓ

PL INSTRUKCJA INSTALACJI

RU ИНСТРУКЦИЯ ПО МОНТАЖУ И ЭКСПЛУАТАЦИИ

RO MANUAL DE INSTALARE

CZ NÁVOD K INSTALACI A POUŽÍVÁNÍ

TR KURULUM KILAVUZU

EL ΟΔΗΓΙΕΣ ΕΓΚΑΤΑΣΤΑΣΗΣ

CN 用户应保留安装指南以备

KR

CE

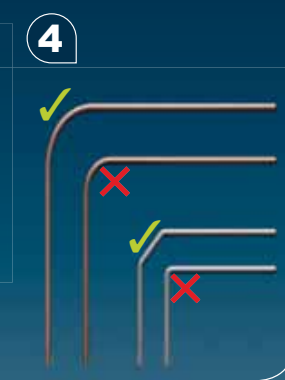
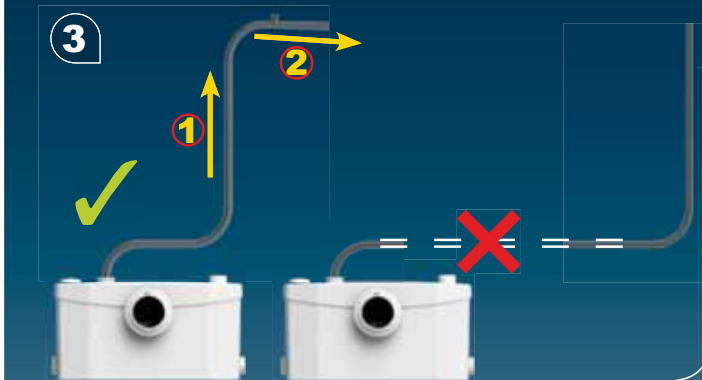
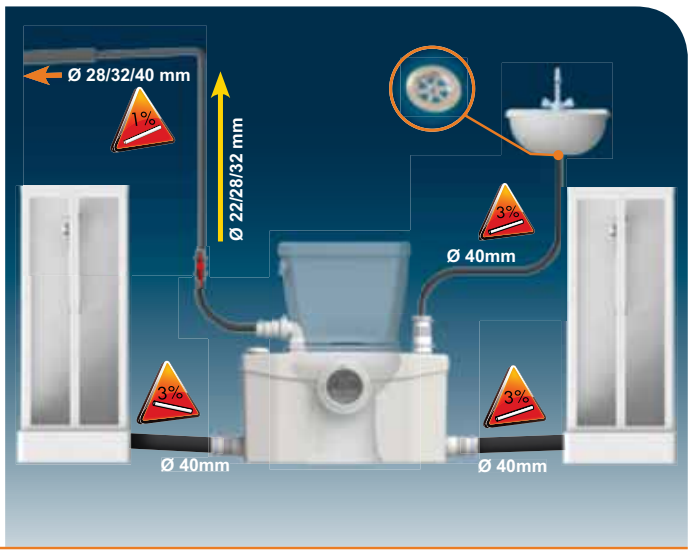

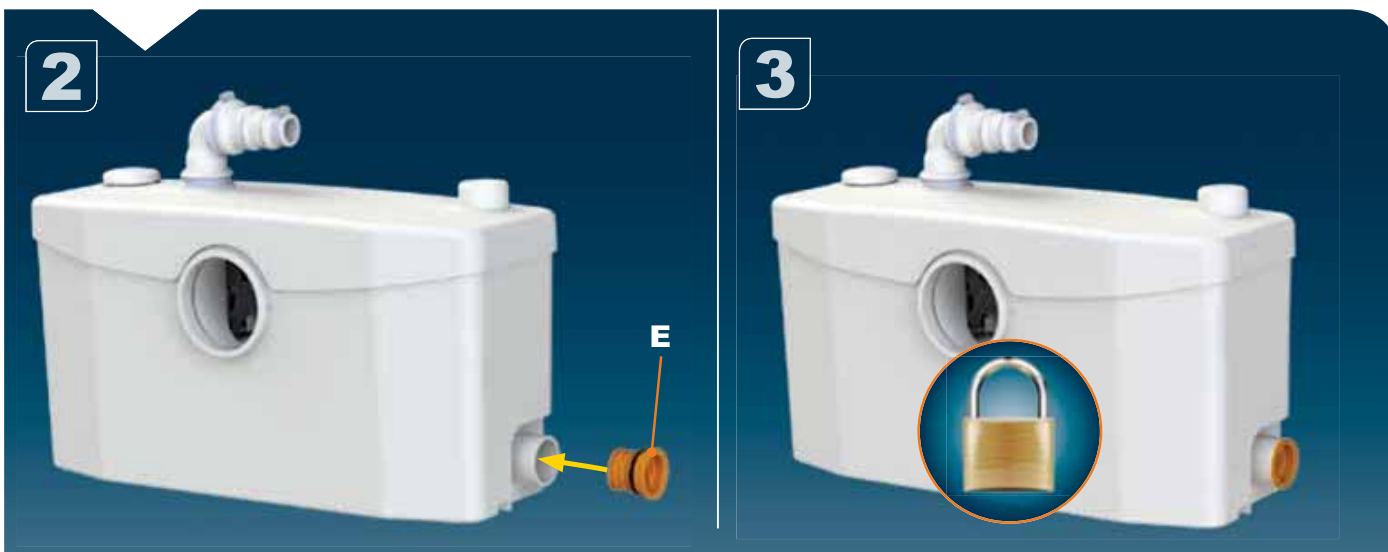
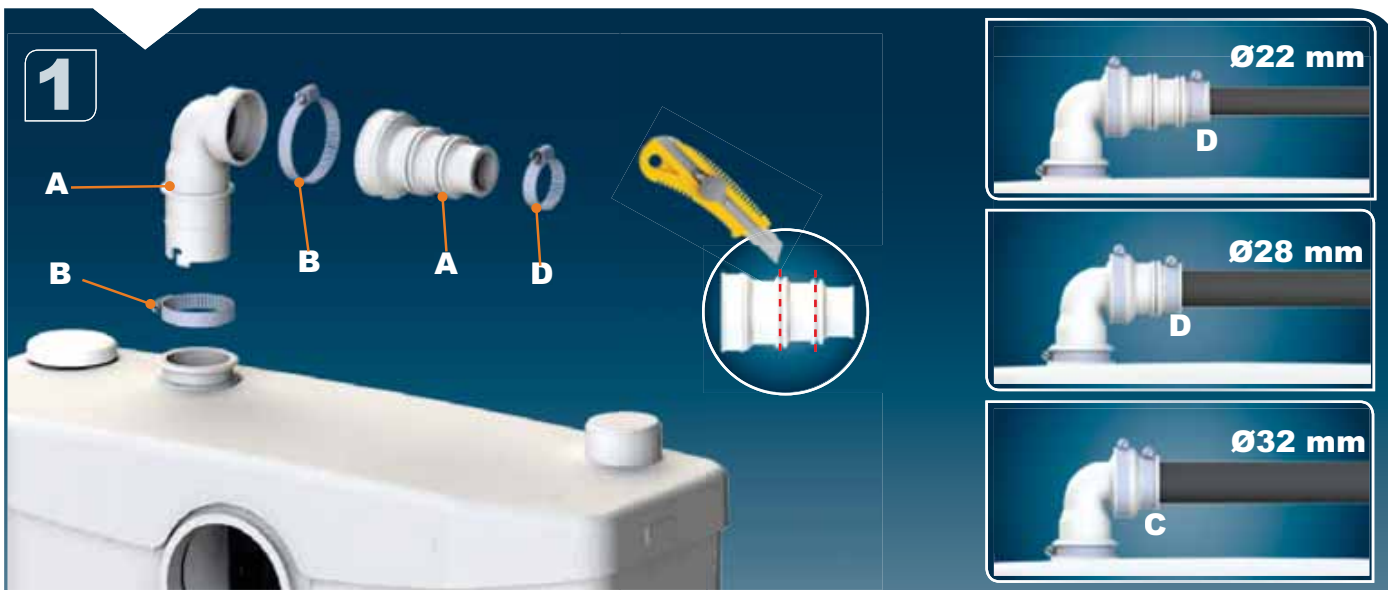
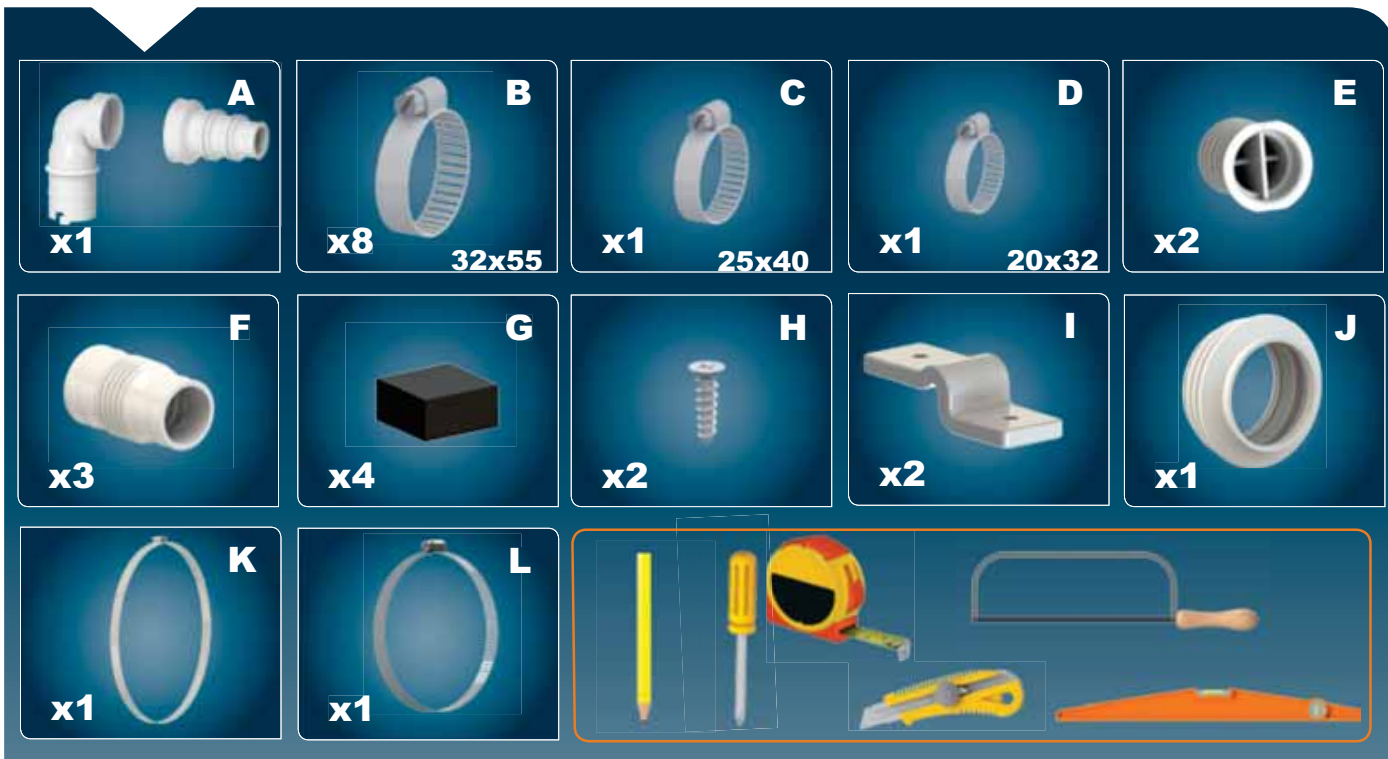

4



5

Ø 40mm

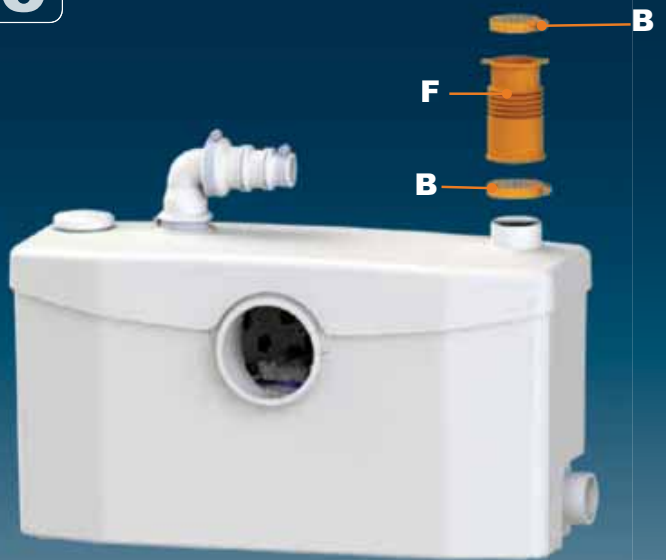

6

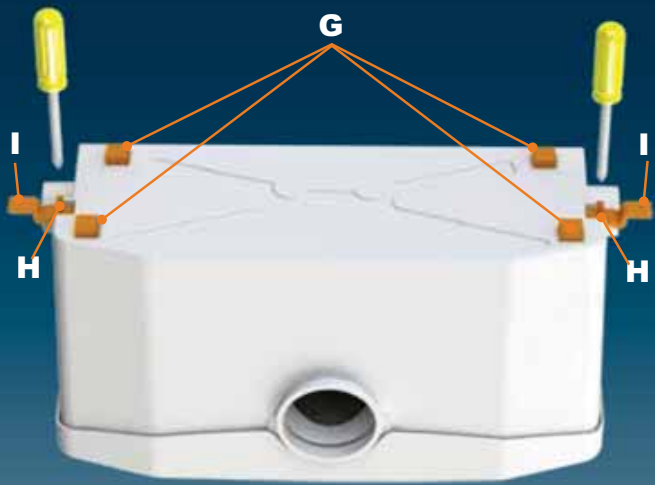

7



8



9



10



11



12

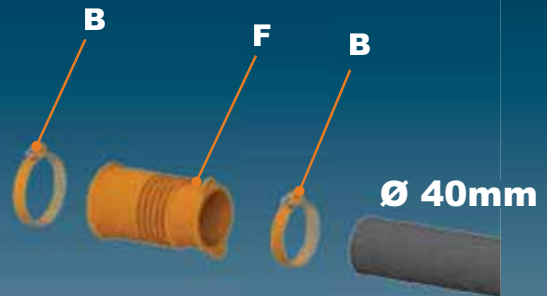

13



Ø 40mm

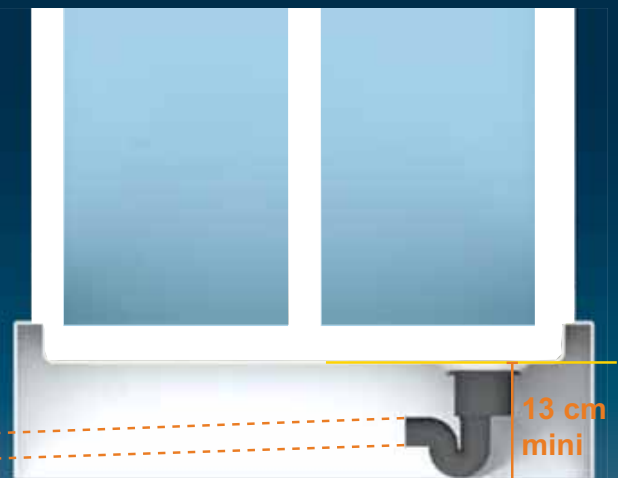

13 cm mini

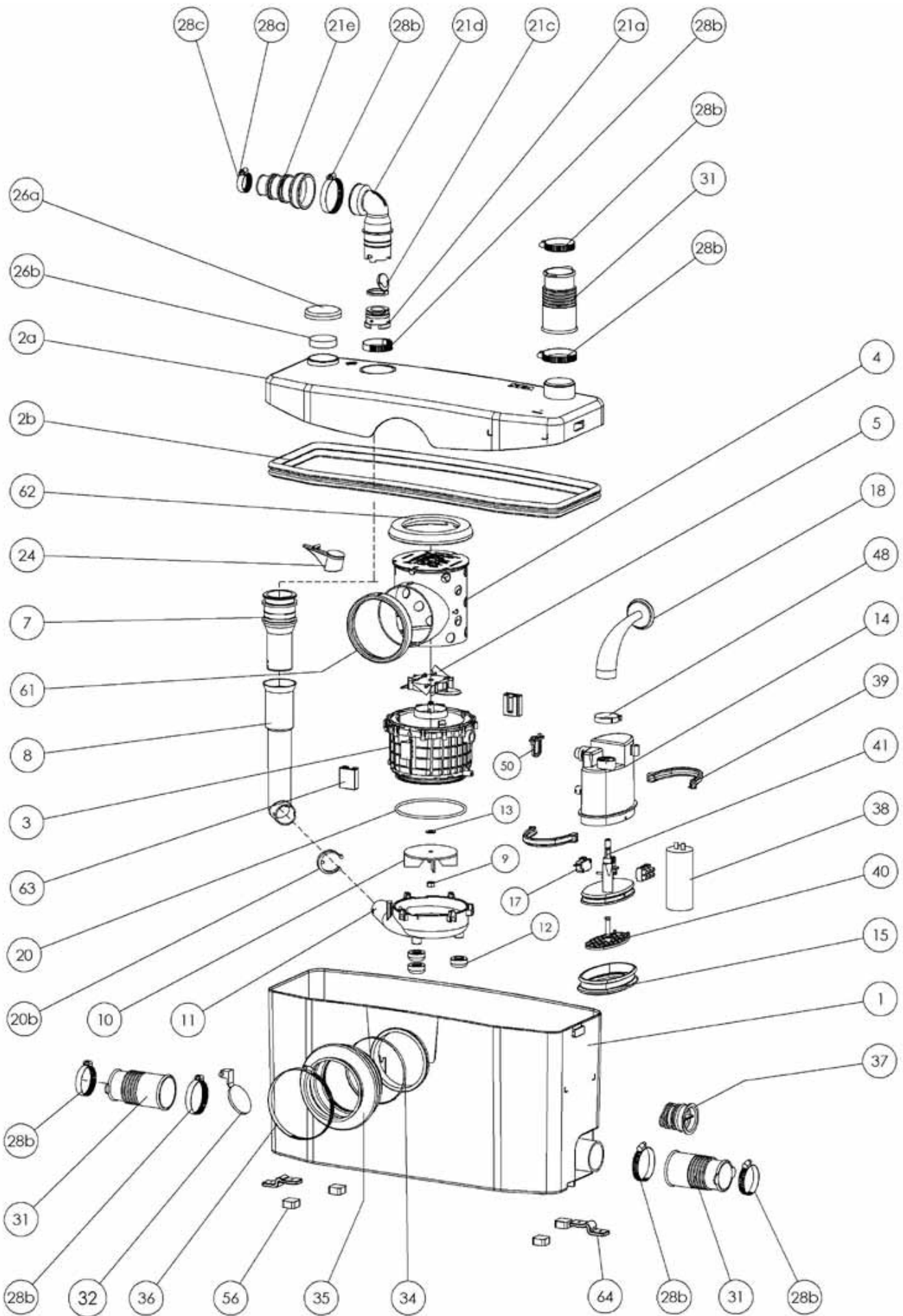

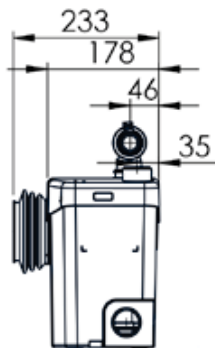
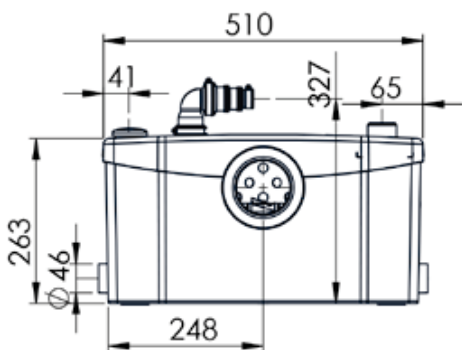
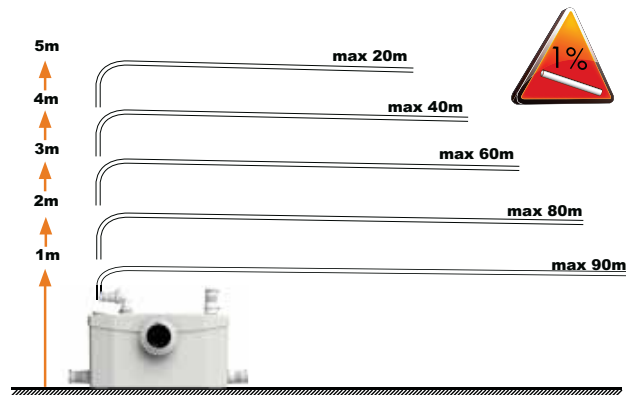
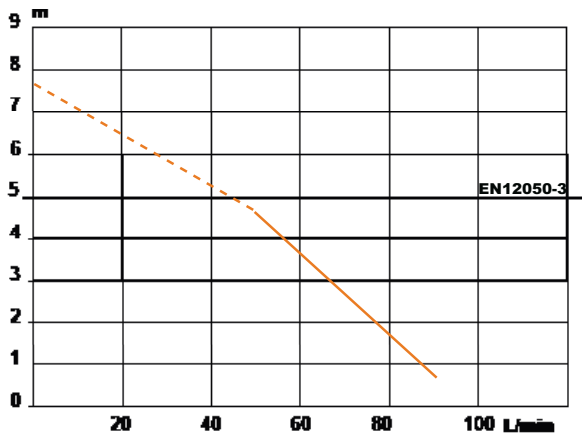

SANIPLUS

EN 12050-3

P 30

220-240 V - 50 Hz

400 W - IP44 - 1,9A -

⚡ (class 1) - 6,4 Kg

FRANCE

**SOCIÉTÉ FRANÇAISE
D'ASSAINISSEMENT**
8, rue d'Aboukir - 75002 Paris
Tél. +33 1 44 82 39 00
Fax +33 1 44 82 39 01

UNITED KINGDOM

SANIFLO Ltd.,
Howard House, The Runway
South Ruislip Middx.,
HA4 6 SE
Tel. +44 208 842 0033/4040
Fax +44 208 842 1671

IRELAND

SANIRISH Ltd
IDA Industrial Estate
Edenderry - County Offaly
Tel. + 353 46 9733 102
Fax + 353 46 97 33 093

AUSTRALIA

SANIFLO AUSTRALIA
Unit 9/10, 25 Gibbes Street Pty Ltd
Chatswood NSW 2067
Tel. +61 298 826 200
Fax +61 298 826 950

DEUTSCHLAND

SFA SANIBROY GmbH
Waldstr. 23 Geb. B5 - 63128
Dietzenbach CH-8954
Tel. (060 74) 30928-0
Fax (060 74) 30928-90

ITALIA

SFA ITALIA spa
Via del Benessere, 9
27010 Siziano (PV)
Tel. 03 82 61 81
Fax 03 82 61 8200

ESPAÑA

GRUPO SFA
C/ Vinyalets, 1 - P.I. Can Vinyalets
08130 Sta. - Perpètua de Mogoda -
Barcelona
Tel. +34 93 544 60 76
Fax +34 93 462 18 96

PORTUGAL

SFA, Lda.
Sintra Business Park, ed.01-1ºP
2710-089 SINTRA
Tel. +351 219 112 785
Fax +351 219 577 000

РОССИЯ

SFA РОССИЯ
101000 Москва - Колпачный переулок,
Тел. (495) 258 29 51
факс: (495) 258 29 51

SUISSE SCHWEIZ SVIZZERA

SFA SANIBROY AG
Steinhaldenstrasse 28
Geroldswill CH-8954
Tel. +41 44 748 17 44
Fax +41 44 748 17 43

BENELUX

SFA BENELUX B.V.
Voltweg 4
6101 XK Echt
Tel. +31 475 487100
Fax +31 475 486515

SVERIGE

SANIFLO AB
BOX 797
S-191 27 Sollentuna
Tel. +08-404 15 30
Fax + 08-404 15 39

POLSKA

SFA POLAND
ul. Kolejowa 33
05-092 Łomianki/Warszawa
Tel. (+4822) 732 00 32
Fax (+4822) 751 35 16

ČESKÁ REPUBLIKA

SFA-SANIBROY, spol. s r.o.
Na Košince - 180 00 PRAHA 8 - Libeň
Tel. +420 266 712 856
Fax, +420 266 712 856

ROMANIA

SFA SANIFLO S.R.L.
Strada Leonard Nicolae, nr. 2A
Timișoara 300454
Tel. +40 256 245 092
Fax +40 256 245 029

TÜRKIYE

SFA SANIHYDRO LTD STI
Ortaklar Caddesi No:7 Ünal Apt. D: 2
34394 MECIDIYEKÖY - İSTANBUL
Tel. +90 212 275 30 88
Fax, +90 212 275 90 58

CHINA

SFA 中国
上海市静安区石门二路333弄3号振安
广场恒安大厦27C室 (200041)
T: +86(0)21 6218 8969
F: +86(0)21 6218 8970

KOREA

www.SFA.biz
sales@saniflo-korea.kr

SERVICE HELPLINES

	TEL	FAX		TEL	FAX
France	☎ N°Azur 0 810 05 90 02 1 lit. par appel	03 44 94 46 19	Benelux	+31 475 487100	+31 475 486515
United Kingdom	08457 650011 (Call from a land line)	020 8842 1671	Sverige	08-744 15 18	08-404 15 39
Ireland	1850 23 24 25 (LOW CALL)	+ 353 46 97 33 093	Norge	+47 951 61 131	
Australia	+61 298 826 200	+61 298 826 950	Poljska	(+4822) 732 00 33	(+4822) 751 35 16
Deutschland	0800 82 27 82 0	(060 74) 30928-90	Россия	(495) 258 29 51	(495) 258 29 51
Italia	0382 6181	+39 0382 618200	Česká Republika	+420 266 712 855	+420 266 712 856
España	+34 93 544 60 76	+34 93 462 18 96	România	+40 256 245 092	+40 256 245 029
Portugal	+351 219 112 785	+351 219 577 000	Türkiye	+90 212 275 30 88	+90 212 275 90 58
Suisse Schweiz Svizzera	+41 44 748 17 44	+41 44 748 17 43	中国	+86(0)21 6218 8969	+86(0)21 6218 8970

Service information : www.sfa.biz

1 DESCRIPTION

This macerator is (manufactured in a factory which is quality) certified to ISO 9001. Installed and used correctly, the unit will give consistent and reliable service.



This device is not designed for persons (including children) with limited physical, sensory or mental abilities, or those with minimal experience and knowledge, unless they are monitored and are given the necessary instructions for using the device, with the help of a person responsible for their safety. Monitor children and make sure they do not play with the device.

2 APPLICATIONS

This appliance is a compact lift pump unit designed for removing waste water from a horizontal outlet toilet*, shower*, bidet* or washbasin* (*: depending on the model). This appliance conforms to EN 12050-3 and the European standards concerning electrical safety and electromagnetic compatibility.

3 INSTALLATION

The unit should be accessible for possible service.

The fitting and working of your appliance must meet local regulations and the EN 12056-4 standard.

To optimise the latest technical developments concerning soundproofing incorporated into this unit, it is important to:

- position the WC pan so that it is not in contact with a partition or wall of the room
- place the WC pan on a perfectly level surface to ensure that the resilient mounts are fully efficient
- fix the discharge pipe correctly, with distances of not more than one metre between the fastenings.

CONNECTION TO THE ELECTRICAL SUPPLY



The electrical installation should be carried out by a qualified person. The unit requires a 220/240V single phase AC 50 Hz supply (UK specification). The power supply circuit of the appliance must be earthed (Class I) and protected by a GFCI high sensitivity (30mA). Warning: Ensure the electricity is turned OFF at the main switch board before wiring to connector.

All wiring must conform to BS7671, 1992 requirements for electrical installations. Do not connect the unit to a conventional plug and socket. **It must be wired into a fused, unswitched, fixed wiring connector fitted with a 5 amp fuse.** The wires in the mains lead are coloured in accordance with

the following code:

Brown - Live
Blue - Neutral
Green/Yellow - Earth

The connection must be used exclusively to power the device.

All work on cable, pressure chamber and motor should only be carried out by a qualified Saniflo servicing agent, as special tools are required. Please do not cut/shorten the electrical supply cable which can make it very difficult to remove in the event of a service requirement.

4 COMMISSIONING THE UNIT

Flush the WC checking that all seals, and connections are watertight.

Check both the discharge pipework from the unit and the other sanitary appliances connections. Check the watertightness of connections to sanitary appliances:

toilet*, shower*, bidet* or washbasin* (*: depending on the model).

5 MAINTENANCE

WARNING !!! In the event of prolonged absence it is essential to turn off the water supply to protect the installation against sub zero temperatures.

CARE OF YOUR UNIT

In order to remove scale and clean the macerator and the bowl, use the SANIFLO Cleanser/Descaler.

.Disconnect the macerator power supply,

.Pour an amount of cleanser into the pan

.Leave it to stand for 1 or 2 hours,

.Re-connect the macerator power supply,

.Rinse by operating the flushing system twice.

Carry out the operation once every 3 months on average, but the frequency may need to be changed depending on the hardness of the water.

6 FAULT FINDING / REMEDIES



IN ALL CASES, YOU MUST DISCONNECT THE MACERATOR FROM THE POWER SUPPLY

SYMPTOMS	PROBABLE CAUSES	REMEDIES
<ul style="list-style-type: none"> • The motor does not activate 	<ul style="list-style-type: none"> • <i>The electrical power supply is not active</i> • <i>The electrical power supply is defective</i> • <i>The motor or the control system is defective</i> 	<ul style="list-style-type: none"> • Restore the electrical supply
<ul style="list-style-type: none"> • The motor emits a rattling or crunching sound, hums, but does not run 	<ul style="list-style-type: none"> • Foreign object into the box • <i>Problem with the motor or the control system</i> 	<ul style="list-style-type: none"> • Remove the foreign body • Otherwise, ask an approved repair agent to intervene
<ul style="list-style-type: none"> • The motor intermittently activates 	<ul style="list-style-type: none"> • <i>The connected sanitary devices are dripping water</i> • <i>The non-return valve is faulty</i> 	<ul style="list-style-type: none"> • Check the installation upstream • Clean or replace the non-return valve
<ul style="list-style-type: none"> • The motor operates normally, but continues to run for a long time 	<ul style="list-style-type: none"> • <i>The length or height of the installation is over the specification, or there are too many bends/elbows</i> • <i>The pump cover plate is partially obscured/blocked</i> 	<ul style="list-style-type: none"> • Check the installation • Otherwise, ask an approved repair agent to intervene
<ul style="list-style-type: none"> • The unit stops 	<ul style="list-style-type: none"> • <i>The unit has been running for too long (thermal cut-out)</i> 	<ul style="list-style-type: none"> • Wait for reset, then ask an approved repair agent to intervene
<ul style="list-style-type: none"> • Motor is surging and water in the WC pan goes down very slowly 	<ul style="list-style-type: none"> • <i>The air dispenser is clogged up</i> • <i>Problem with motor</i> 	<ul style="list-style-type: none"> • Clear the air relief hole • Otherwise, ask an approved repair agent to intervene
<ul style="list-style-type: none"> • Cloudy water comes up into the shower basin (units with side inlets) 	<ul style="list-style-type: none"> • <i>Shower installed too low as compared with the macerator unit</i> • <i>Hinged side inlet discs clogged up</i> 	<ul style="list-style-type: none"> • Check the installation • Clean the hinged discs • Otherwise, ask an approved repair agent to intervene

7 GUARANTEE

2 years guarantee as from its date of purchase subject to correct installation and correct use.



Only the disposal of toilet paper, faecal matter, and waste water will be under guarantee. Any damage due to foreign bodies such as cotton, condoms, sanitary towels, wet wipes, food, hair, metal, wood or plastic objects, will not be under guarantee. Solvents, acids and other chemicals can also cause damage to the unit, and will invalidate the guarantee.

